 = 1 sq foot

General Setup Instructions

- Read entire setup instruction manual prior to unpacking parts and pieces.
- The setup instructions are created specifically for this configuration.
- Setup instructions are laid out sequentially in steps, including exploded views with detailed explanation for assembly.

Cleaning & Packing

- For Cleaning Metal, Plex, & Laminate Parts: Use a **MILD NON-ABRASIVE** cleanser and soft cloth/paper towel to clean all surfaces.
- Keep exhibit components away from heat and prolonged sun exposure. **Heat and UV exposure will warp and fade components.**
- Retain all provided Packing Materials. All provided packing materials are for ease of repacking & component protection.

Disassembly

- For loss prevention, tighten all set screws and locks during disassembly.

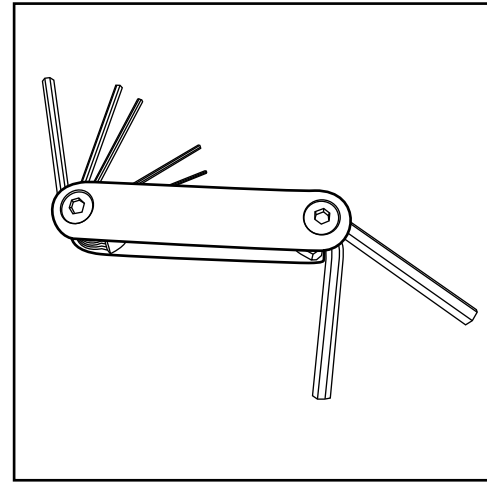

Hex Tool - Essential for Assembly

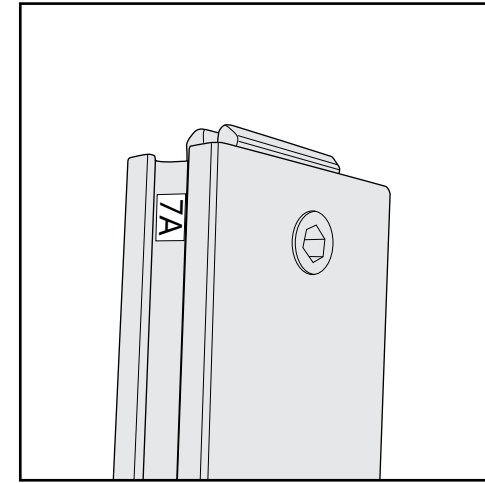

Part Identification - Numbering

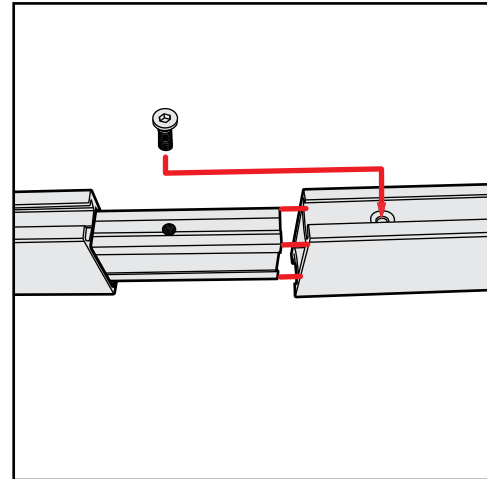

Spline Connection

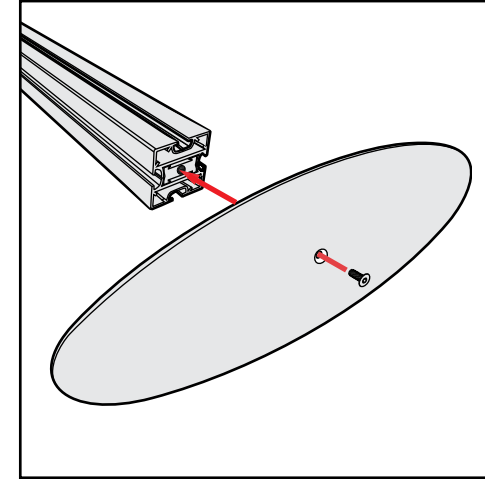

Base Plate & Extrusion Connection

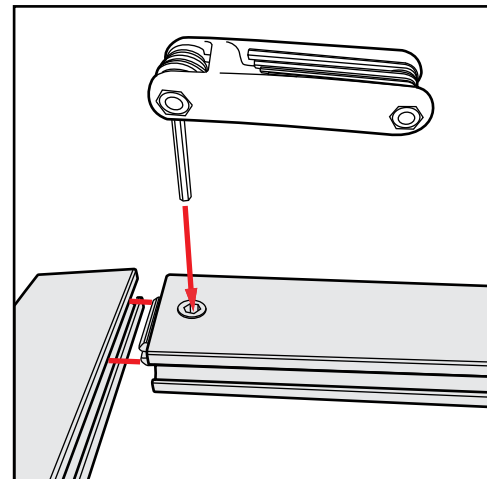

Extrusion & Lock Connection

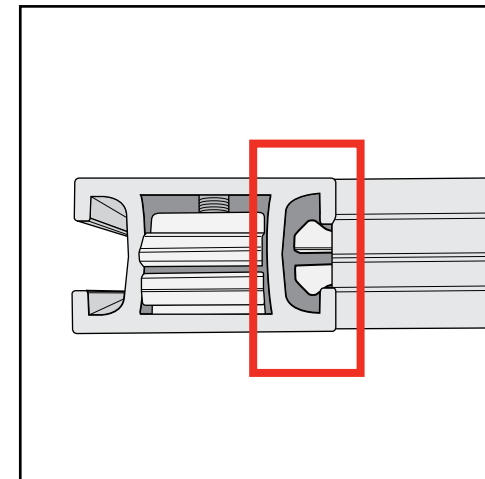

Engaged Lock



WARNING



DO NOT USE POWER TOOLS

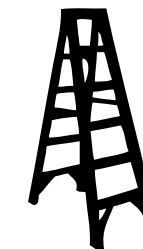

LADDERS OR LIFTS
MAY BE REQUIRED



ALL CONNECTIONS MUST
BE TIGHTLY SECURED



Side-by-Side Assembly

- 1) Frames: Place frames side-by-side with one higher than the other, then slide panel down to lock panels securely together.
- 2) Corner Connectors: Repeat Step 1 for installing corner connectors to frames.

Side-by-Side Disassembly

- 1) Pull pin lock outwards to disengage.
- 2) Pull frames upward and apart at the same time to detach.

Assembly

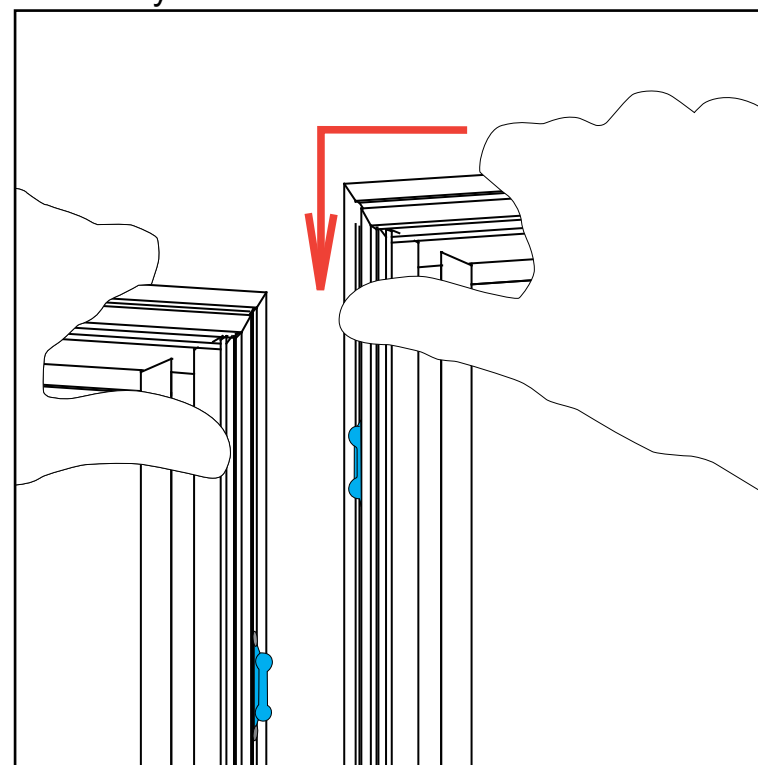

Assembly Cont'd

Push pin lock into hole of connecting frame.
Note: Block of pin lock will secure in groove.

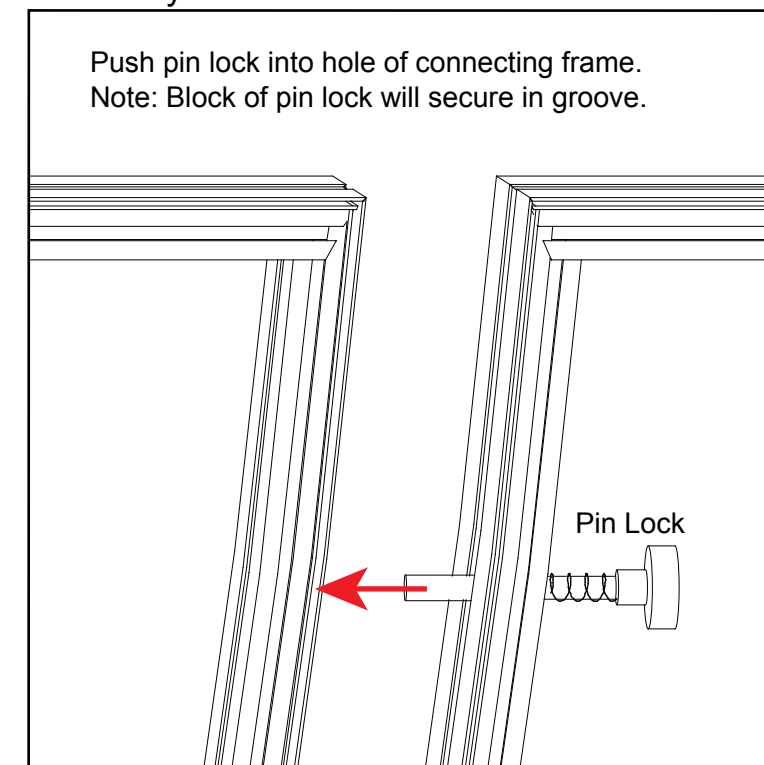

Corner Connector

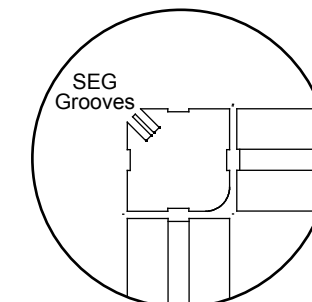

Top View

Note: Orientation of Corner Connector may change.

Stacking Assembly

- 1) Place one horizontal frame on top of the other, lining up the center grooves.
- 2) Turn stacking lock clockwise to tighten into place. Repeat for each lock.

Stacking Disassembly

- 1) Turn the stacking lock counter-clockwise to loosen.
- 2) The whole spring on the stacking lock should be in view to release each frame. The disengaged spring should release the stacking lock. If not, keep turning the stacking lock until it disengages.

Stacking

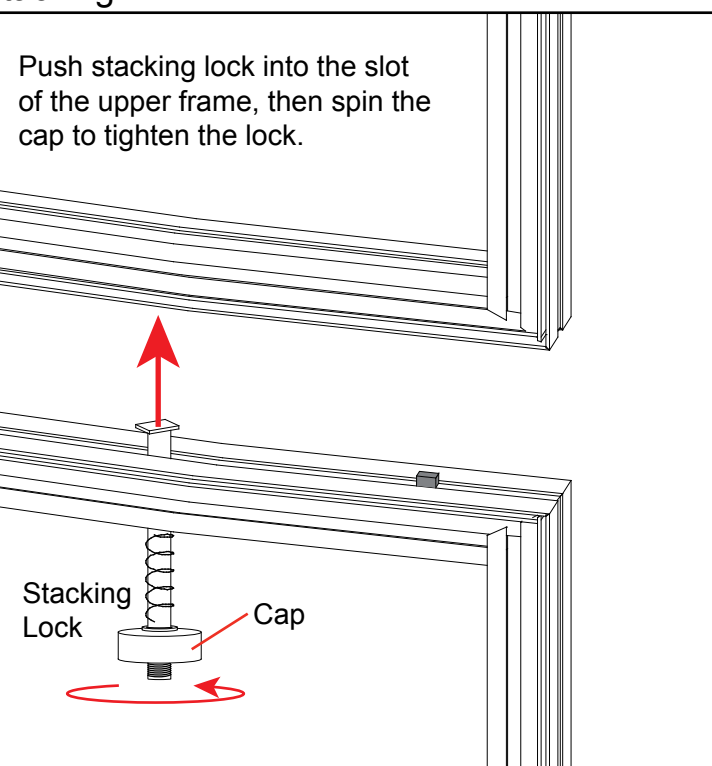

Push stacking lock into the slot of the upper frame, then spin the cap to tighten the lock.

Unstacking

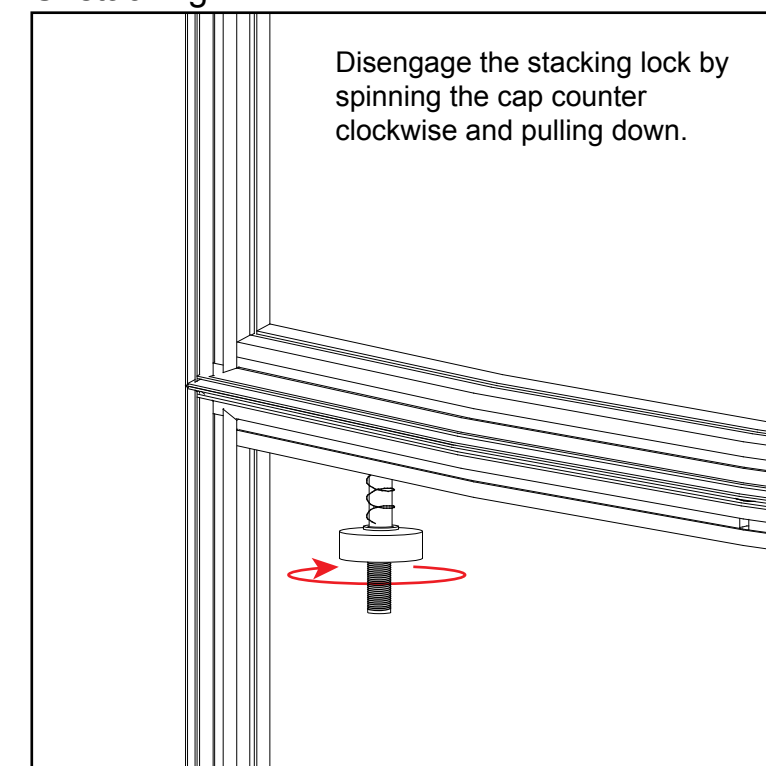

Disengage the stacking lock by spinning the cap counter clockwise and pulling down.

Straight Connection

When assembling frame, first attach all **straight connectors**, then attach **corner connectors**.

- 1) Place extrusions end-to-end.
- 2) Loosen all knobs, then slide **straight connectors** across the seam of extrusions.
- 3) Tighten all knobs to secure connection.

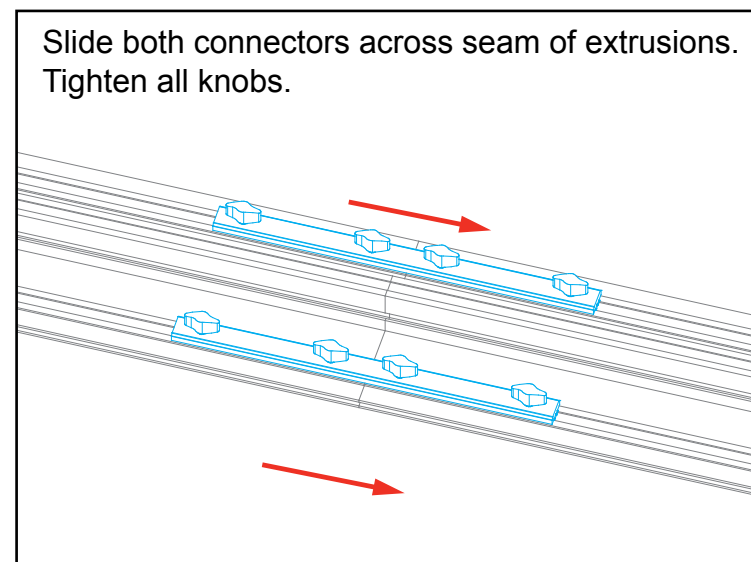
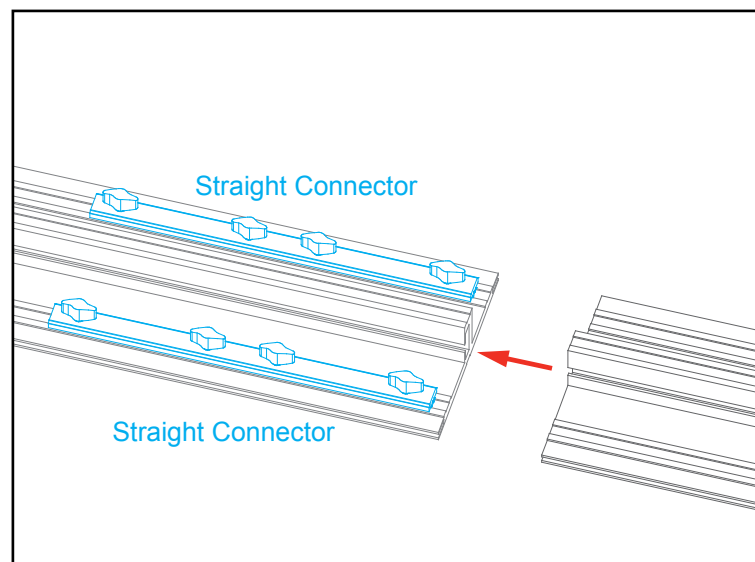

All knobs must be tightened securely to ensure a proper connection.

Disassembly

- 1) Loosen all knobs.
- 2) Slide connectors off of one extrusion.
- 3) Tighten knobs to prevent loss during packing & shipping.

Keep straight connectors in groove of extrusion. Do not remove connectors during disassembly.

Corner Connection

- 1) Loosen knobs, then slide vertical extrusions onto **corner connectors** of **lower** horizontal extrusion.
- 2) Slide **corner connectors** of **upper** horizontal extrusion into grooves of vertical extrusions.
- 3) Tighten all knobs to secure connection.

Disassembly

- 1) Loosen knobs on vertical extrusions.
- 2) Slide the vertical extrusions off of **corner connectors** on lower and upper horizontal extrusions.

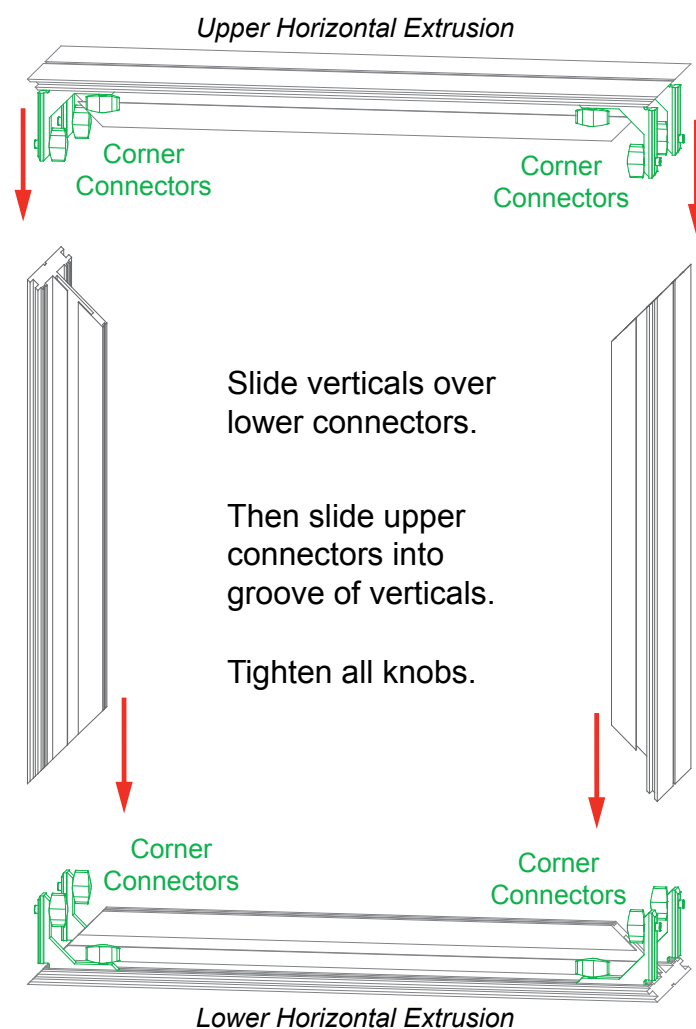

Adjust connectors if necessary to prevent gaps in connection.

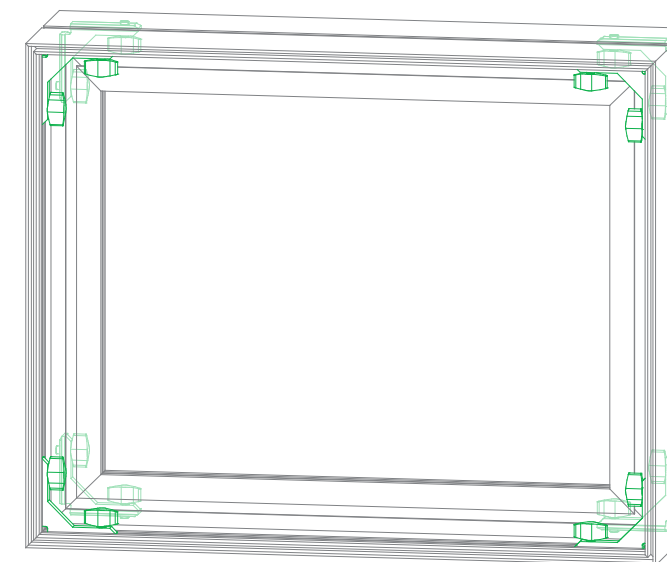

COMPLETED ASSEMBLY

All knobs must be tightened securely to ensure a proper connection.

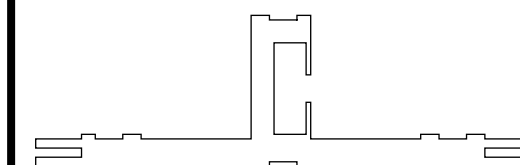

CEI152 Profile

Straight Connection

When assembling frame, first attach all **straight connectors**, then attach **corner connectors**.

- 1) Place extrusions end-to-end.
- 2) Loosen all knobs, then slide **straight connectors** across the seam of extrusions.
- 3) Tighten all knobs to secure connection.

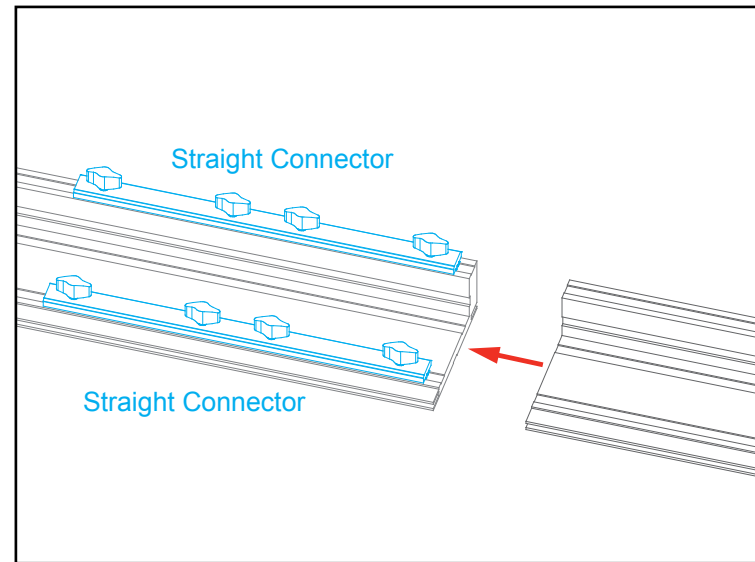

Slide both connectors across seam of extrusions. Tighten all knobs.

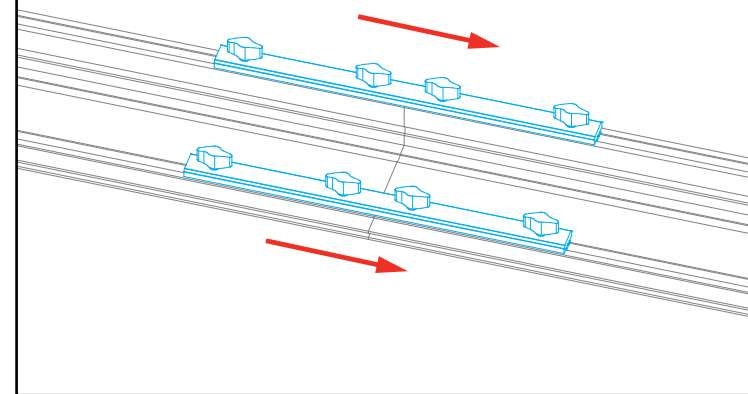

All knobs must be tightened securely to ensure a proper connection.

Disassembly

- 1) Loosen all knobs.
- 2) Slide connectors off of one extrusion.
- 3) Tighten knobs to prevent loss during packing & shipping.

Keep straight connectors in groove of extrusion. Do not remove connectors during disassembly.

Corner Connection

- 1) Loosen knobs, then slide vertical extrusions onto **corner connectors** of **lower** horizontal extrusion.
- 2) Slide **corner connectors** of **upper** horizontal extrusion into grooves of vertical extrusions.
- 3) Tighten all knobs to secure connection.

Disassembly

- 1) Loosen knobs on vertical extrusions.
- 2) Slide the vertical extrusions off of **corner connectors** on lower and upper horizontal extrusions.

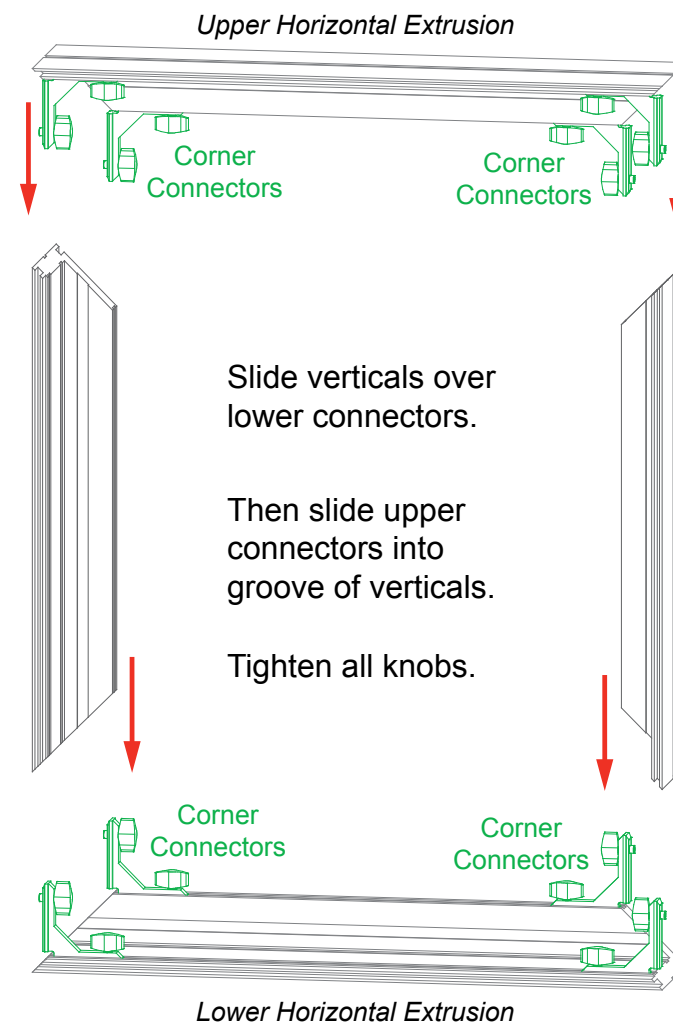

Slide verticals over lower connectors.

Then slide upper connectors into groove of verticals.

Tighten all knobs.



Adjust connectors if necessary to prevent gaps in connection.

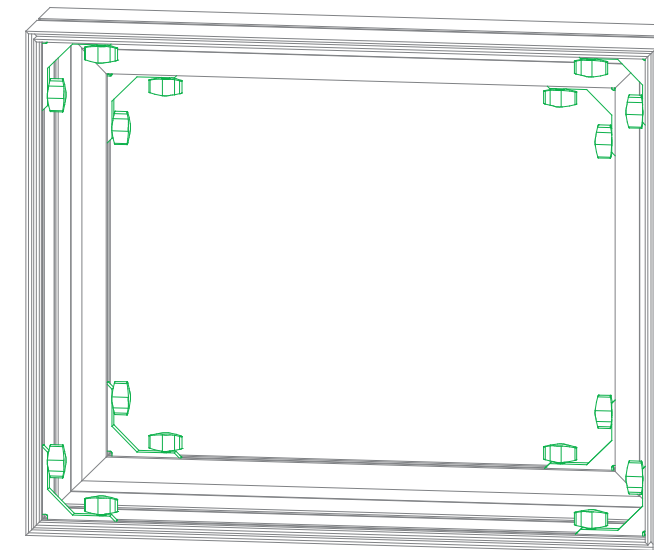

COMPLETED ASSEMBLY

All knobs must be tightened securely to ensure a proper connection.

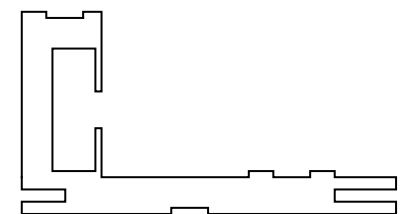

CEI110 Profile

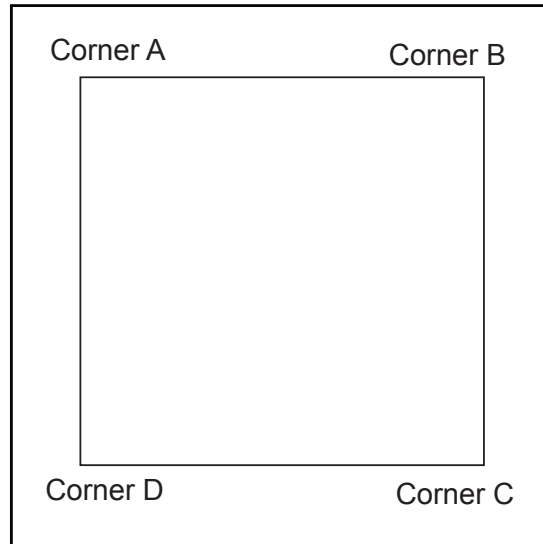

It is important to first insert graphic into each alternate corner then to the sides of the frame. If this is not done, graphic will not fit into the frame correctly.

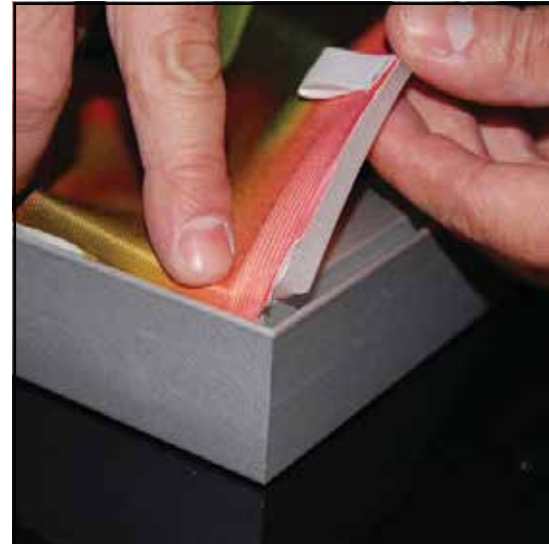

Step 1
Insert corner A. Turn edge of graphic so silicon welt is perpendicular to face of graphic. Insert narrow side of welt with fabric to outside into the channel. Repeat for other side of this corner.



Step 2
Repeat Step 1 for opposite corner C, then insert corner B, followed by corner D, to complete the installation of the corners.



Step 3
Once all corners are inserted, press one silicon edge into channel from corners and work toward the center. Make sure welt is fully inserted into channel. Continue until all sides are done. Smooth out edges of graphic.

Graphic Removal

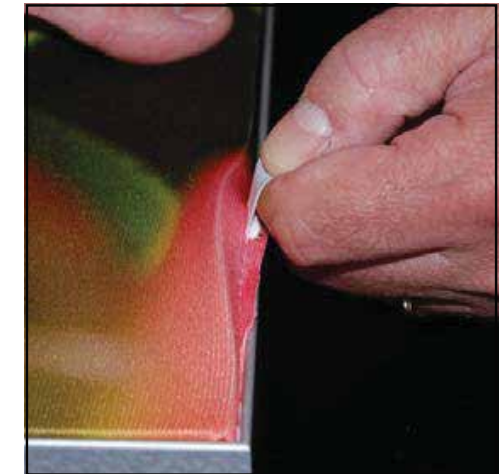

To remove the graphic from the frame, locate the fabric pull tab. Gently pull up on the tab to remove the fabric.

Item	Qty.	Description
2	2	95”h CEI152 Vertical Extrusion
4	2	95”h CEI152 Vertical Extrusion
6	2	48”w CEI152 Horizontal Extrusion
7	2	48”w CEI152 Horizontal Extrusion
8	2	44.353”w Z45 Horizontal Extrusion
9	2	72”h Z45 Vertical Extrusion
10	2	72”h Z45 Vertical Extrusion

Steps:

Refer to the CEI152 Frame Assembly general information page.

- 1) Assemble verticals [2,4] between horizontals [6,7] using corner connectors.
- 2) Connect horizontal [8] between verticals [2,4].
- 3) Attach verticals [9,10] between horizontals [6,8].

Repeat steps 1 through 3 for other kiosk frame assembly.

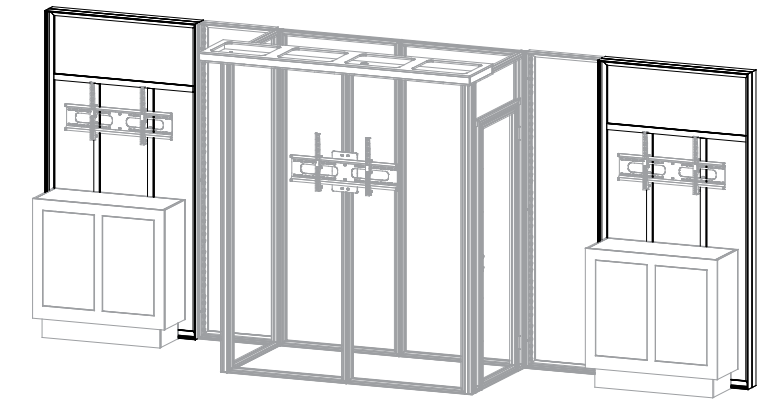

Section Being Assembled is Highlighted in BLACK

Assemble frames flat on ground.

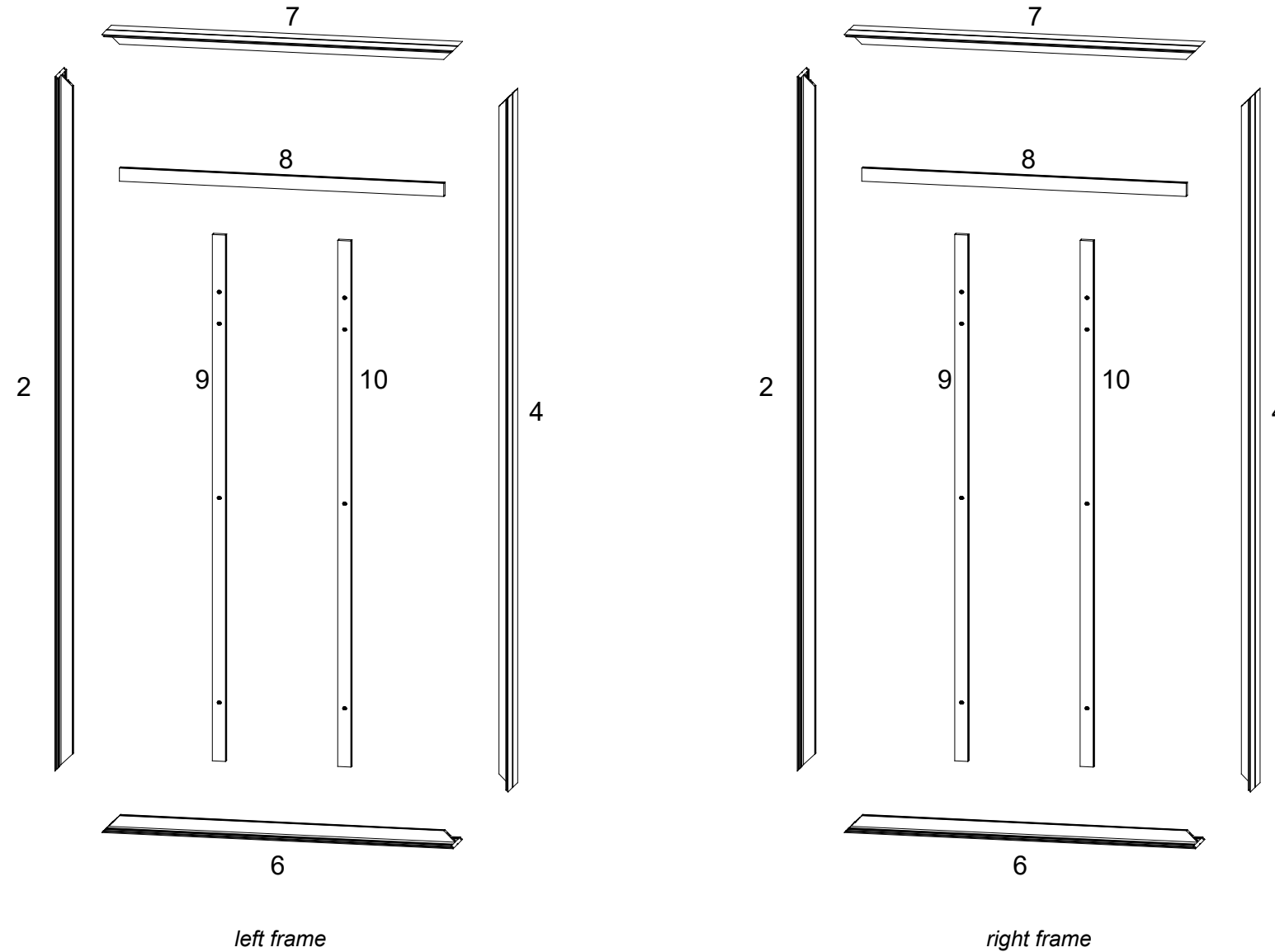

FRONT VIEW

Item	Qty.	Description
1	1	95”h CEI110 Vertical Extrusion
2	1	95”h CEI110 Vertical Extrusion
3	1	24”w CEI110 Horizontal Extrusion
4	1	24”w CEI110 Horizontal Extrusion
5	1	95”h CEI110 Vertical Extrusion
6	1	95”h CEI110 Vertical Extrusion
7	1	24”w CEI110 Horizontal Extrusion
8	1	24”w CEI110 Horizontal Extrusion

Steps:

Refer to the CEI110 Frame Assembly general information page.

- 1) Assemble verticals [1,2] between horizontals [3,4] using corner connectors.
- 2) Attach verticals [5,6] between horizontals [7,8].
- 3) Connect power cords to Supernova lights.

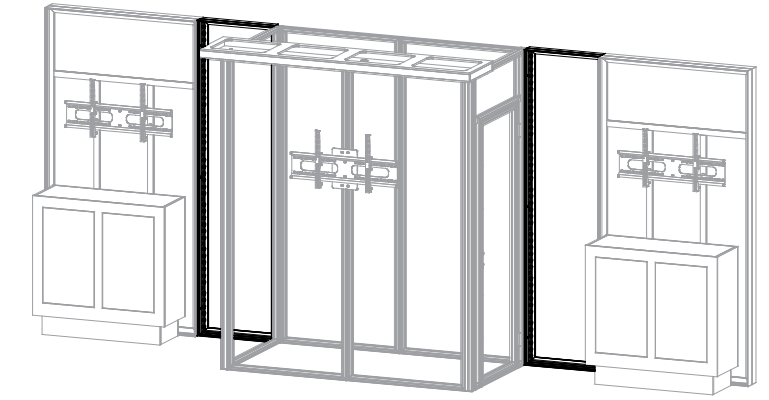

Section Being Assembled is Highlighted in BLACK

Assemble frames flat on ground.

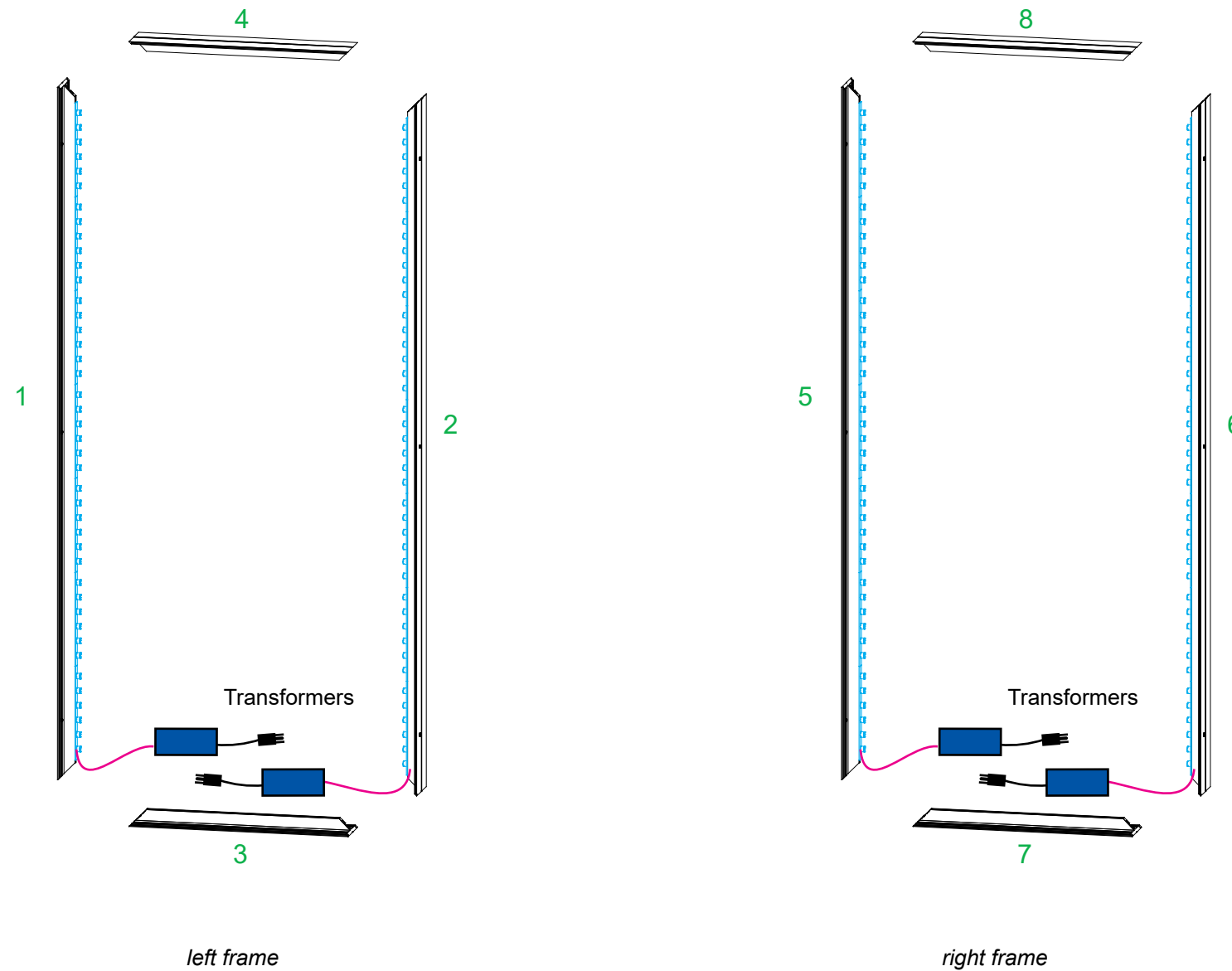
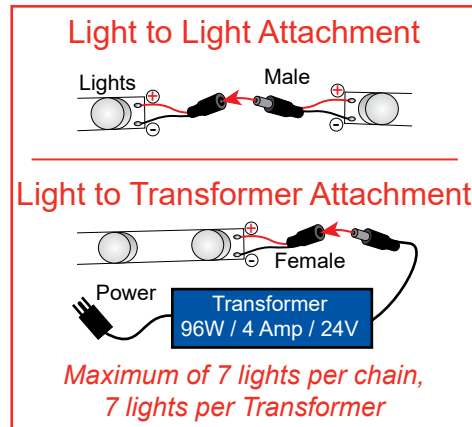

FRONT VIEW

Item	Qty.	Description
1	1	38"w x 95"h lower Gravitee Panel
2	1	94.5"h lower Gravitee Corner Post w/ caps
3	1	38"w x 95"h lower Gravitee Panel
4	1	38"w x 95"h lower Gravitee Panel
5	1	94.5"h lower Gravitee Corner Post w/ caps
6	1	38"w x 95"h lower Gravitee Panel w/ Door
7	1	94.5"h lower Gravitee Corner Post w/ caps
8	1	38"w x 95"h lower Gravitee Panel
9	1	38"w x 95"h lower Gravitee Panel
10	1	94.5"h lower Gravitee Corner Post w/ caps

Steps:

Refer to the Gravitee Assembly general information page.

- 1) Assemble Gravitee posts & panels [1] through [10] together in numerical order as shown.

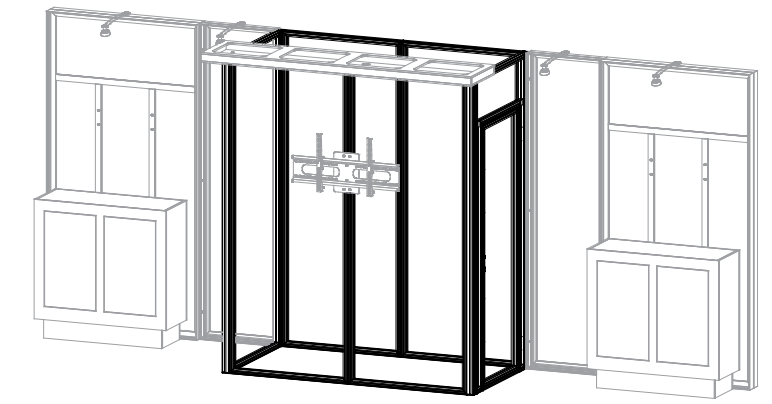

Section Being Assembled is Highlighted in BLACK

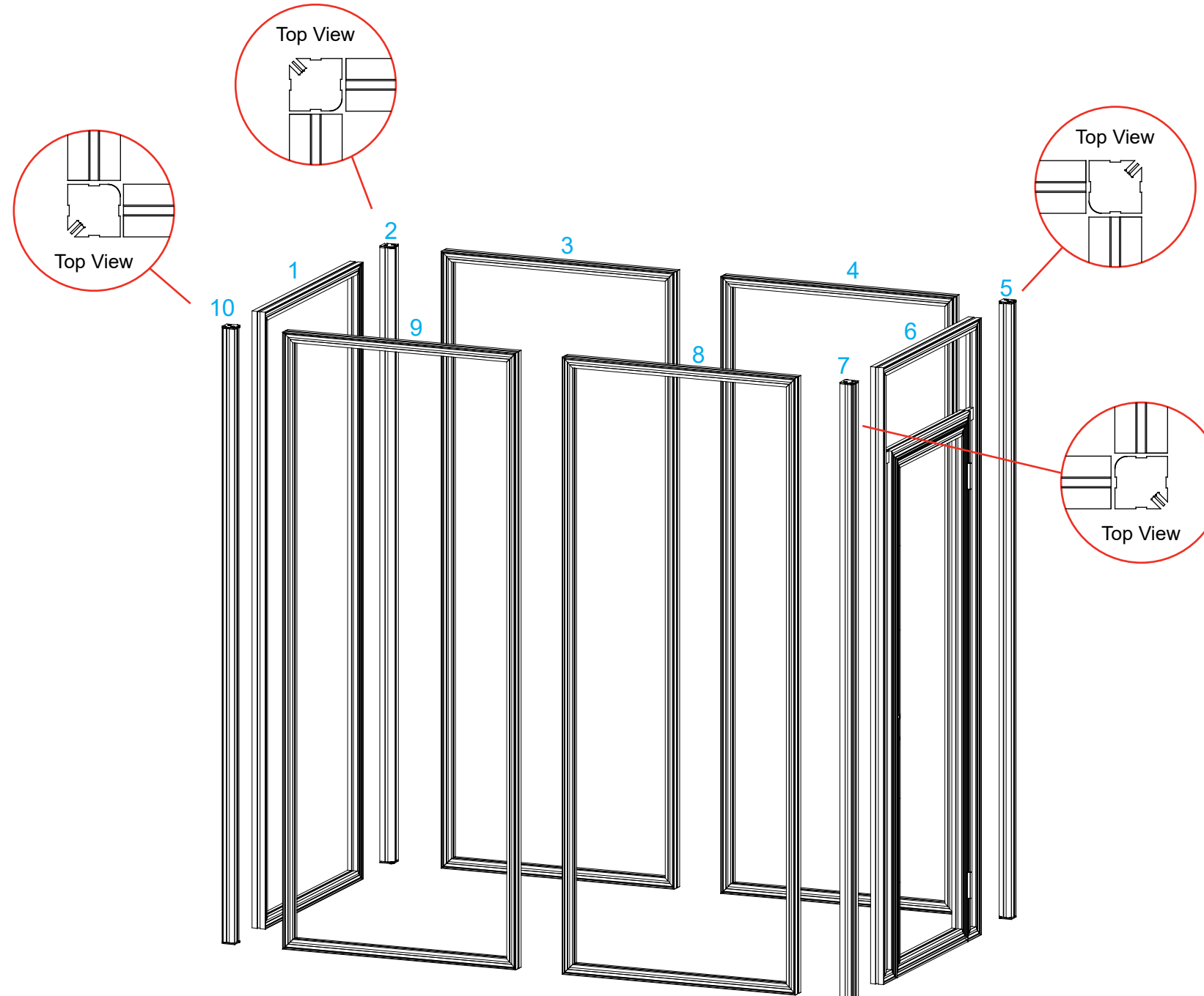

SEG Graphic Installation

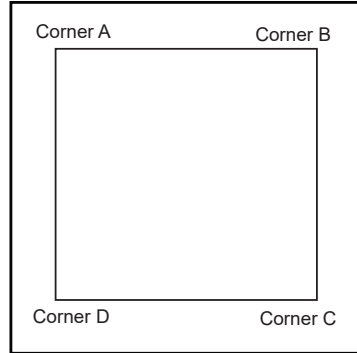

It is important to first insert graphic into each alternate corner, then to the sides of the frame. If this is not done, graphic will not fit into the frame correctly.

Step 1
Insert corner A. Turn edge of graphic so silicon welt is perpendicular to face of graphic. Insert narrow side of welt with fabric to outside into the channel. Repeat for other side of this corner.



Step 2
Repeat Step 1 for opposite corner C, then insert corner B, followed by corner D, to complete the installation of the corners.



Step 3
Once all corners are inserted, press one silicon edge into channel from corners and work toward the center. Make sure welt is fully inserted into channel. Continue until all sides are done. Smooth out edges of graphic.



Graphic Removal

To remove the graphic from the frame, locate the fabric pull tab. Gently pull up on the tab to remove the fabric.

Steps:
1) Apply SEG graphics to assembled frames & closet.

Note: Graphics & Blocker must be attached to closet assembly before connecting backwall panels.

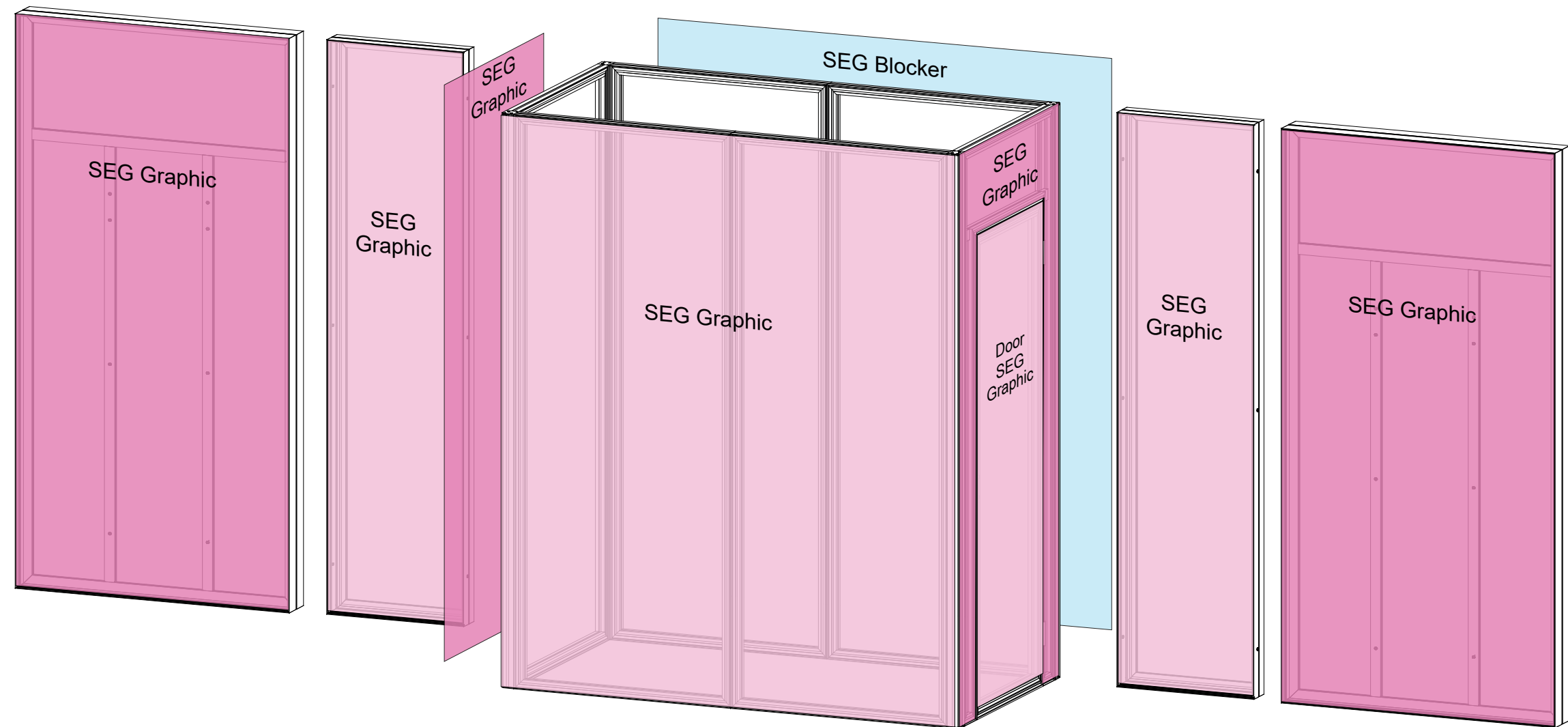

Steps:

- 1) Attach left Small Frame vertical [1] to left large frame vertical [4] using bolts & V4 connectors. See Bolt to V4 Connection detail.
- 2) Connect left Small Frame vertical [2] to Closet post [2]. See Bolt to V4 Connection detail.
- 3) Attach right Small Frame vertical [6] to right large frame vertical [2]. See Bolt to V4 Connection detail.
- 4) Connect right Small Frame vertical [5] to Closet post [5]. See Bolt to V4 Connection detail.

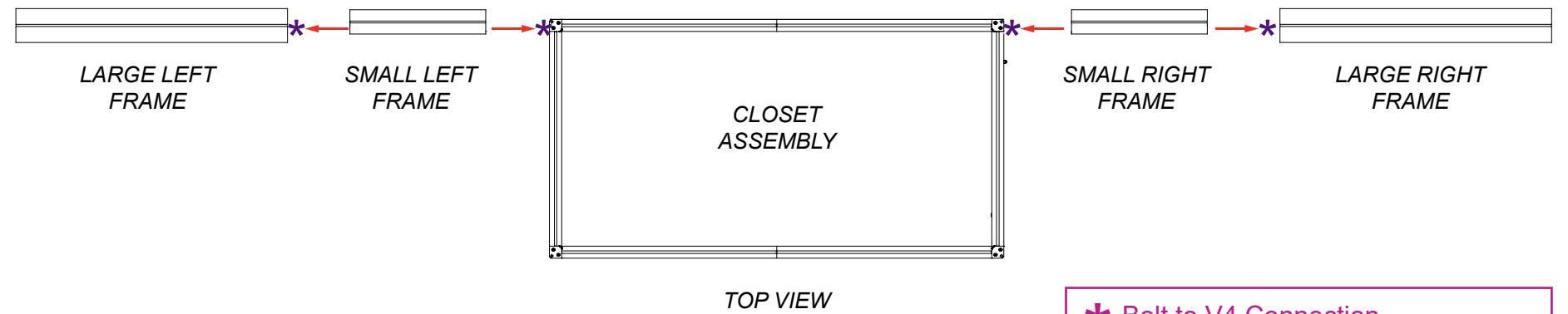

Note: Graphics & Blocker must be attached to closet assembly before connecting backwall panels.

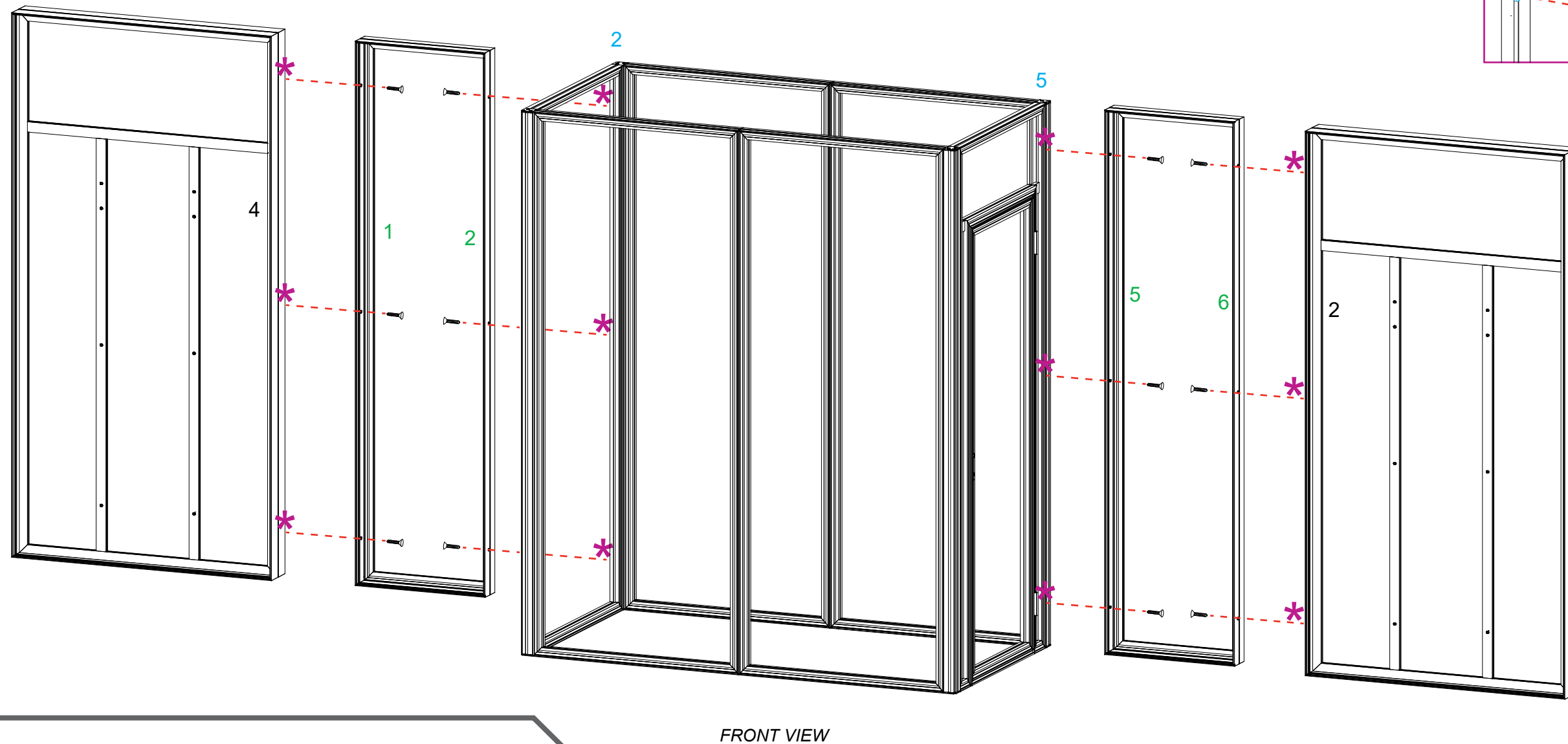
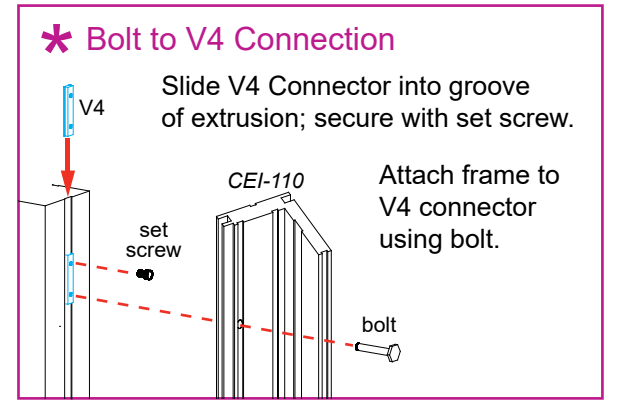

Item	Qty.	Description
A	1	86" w x 18" d x 3" h Canopy Panel

*** Puck Light Connection**

Connect transformer to puck lights, then attach transformer to power source.

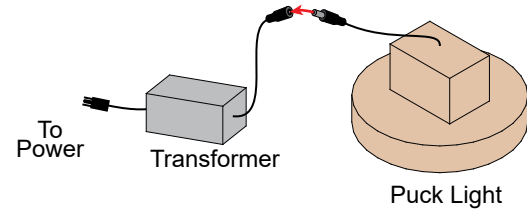

Steps:

- 1) Attach Ceiling Panel [A] to top of Gravitee closet, using Bolts & V4 connectors See **Ceiling Attachment** detail.
- 2) Connect power cords to puck lights in ceiling panels. See **Puck Light Connection** detail.

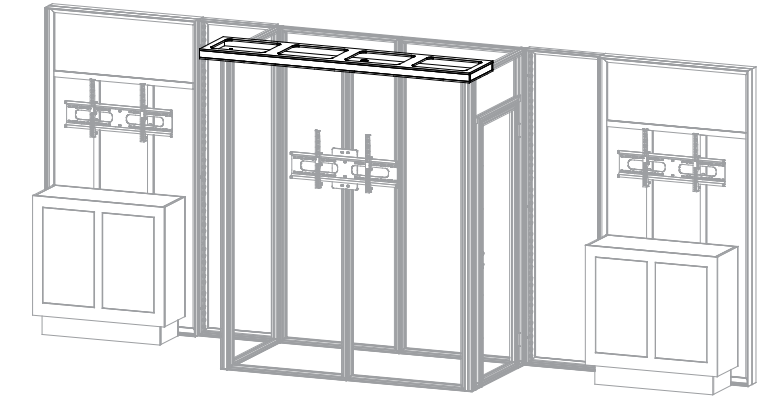

Section Being Assembled is Highlighted in BLACK

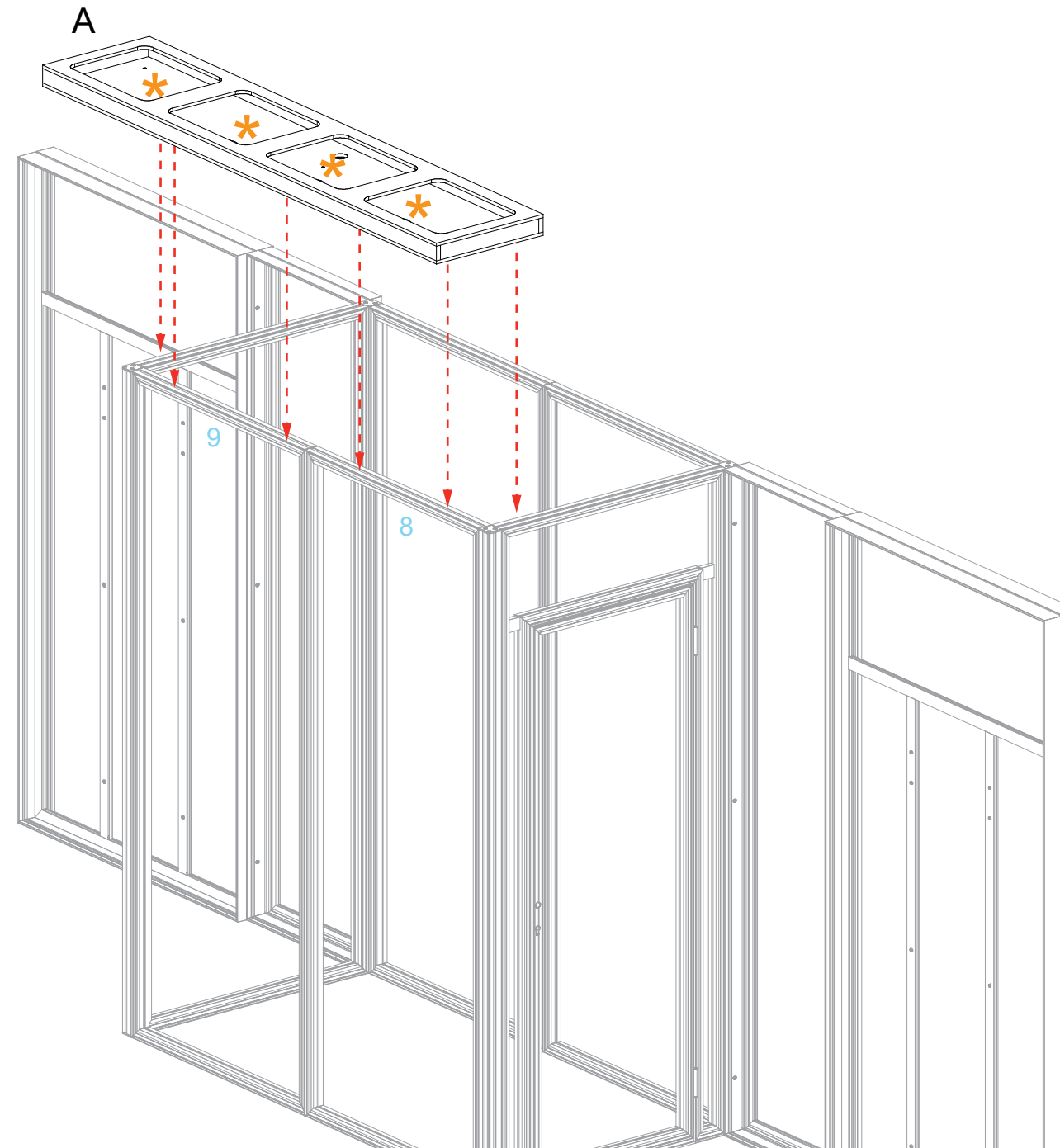

Ceiling Attachment

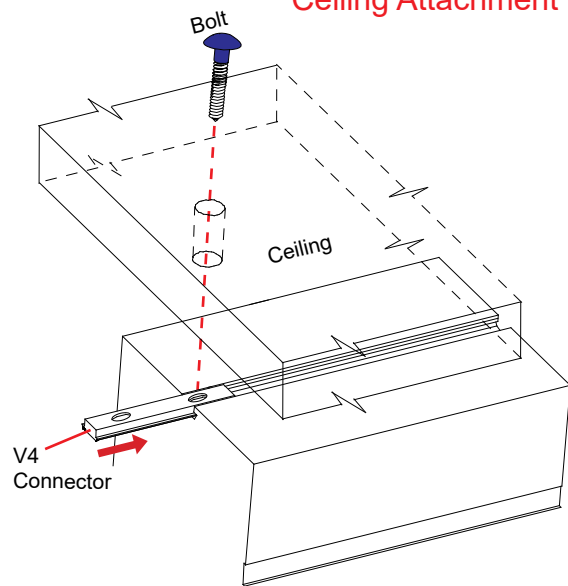

Slide V4 connector into groove of Gravitee panel; tighten set screw to secure V4 connector in place at correct location. Insert bolt through hole of ceiling into threaded hole of V4 connector; tighten screw to secure.

Item	Qty.	Description
--	2	42"w x 16"d x 42"h Kiosk Counter

Steps:

- 1) Connect counters to verticals [9,10] of left & right frame assemblies, using Standoff Barrels.
See [Standoff Barrel Attachment](#) detail.
- 2) Attach lights to top of backwall where shown.
See [Light Attachment](#) detail.

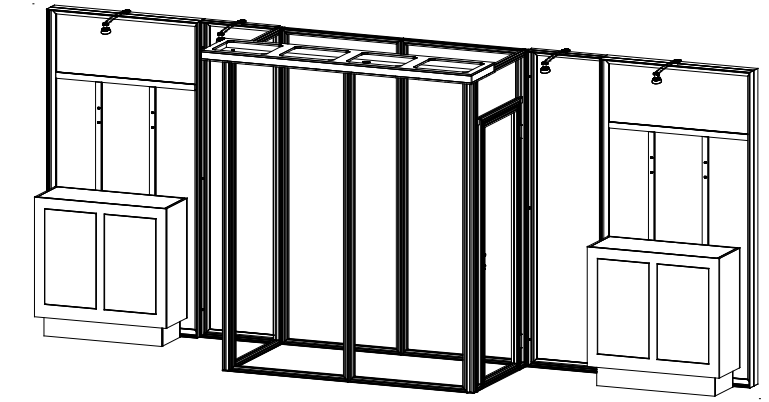

When assembled

*** Standoff Barrel Attachment**

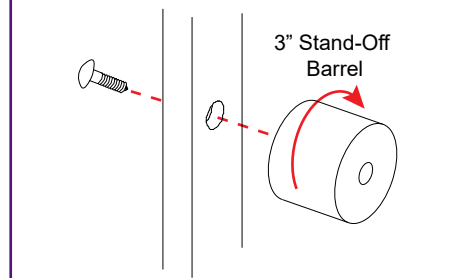

Secure Counter to vertical extrusion using standoff barrels.

*** Light Attachment**

Lock Clip into Groove of Horizontal Extrusion, then slide Light onto Clip.



Slide light into light receiving hardware

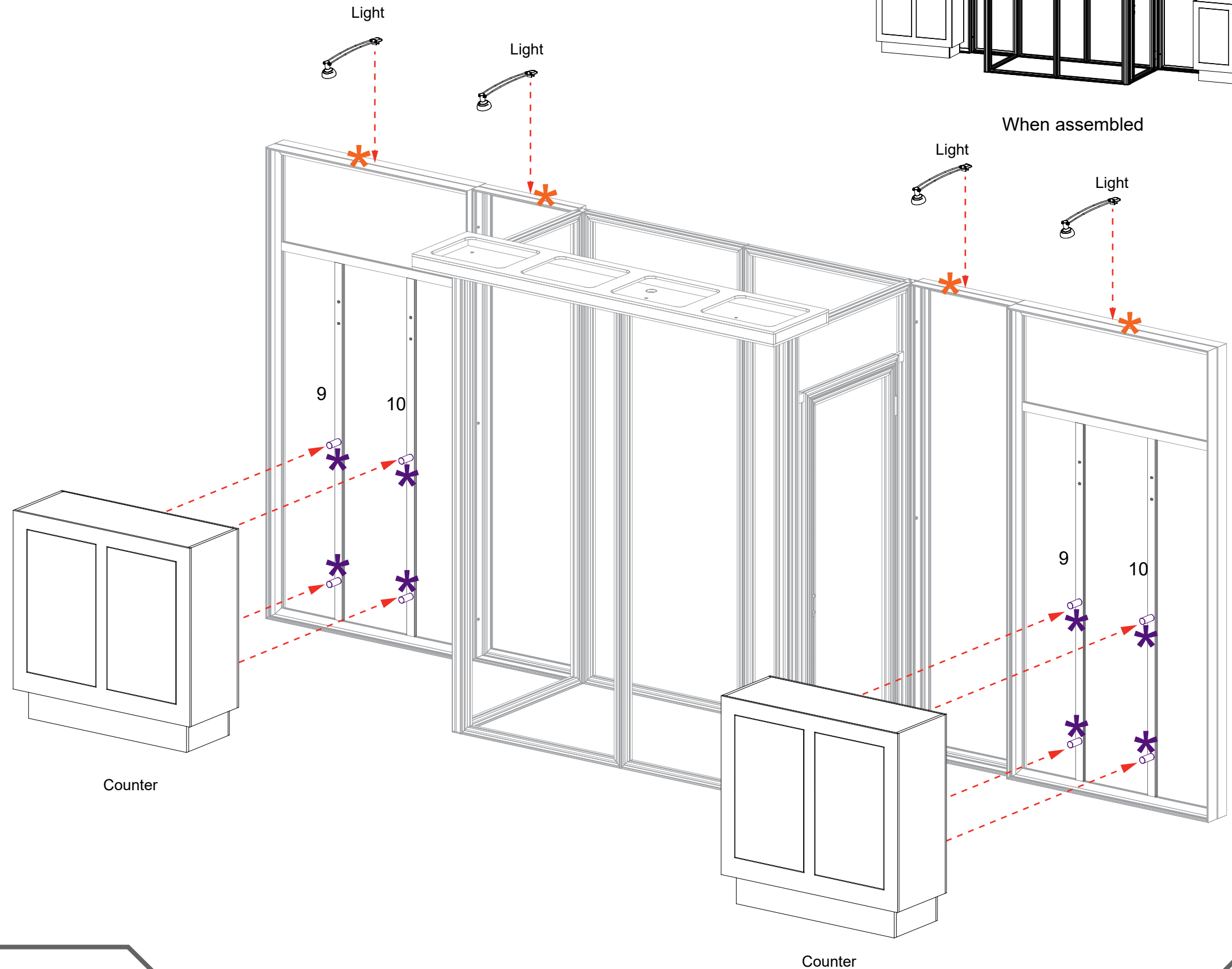

Item	Qty.	Description
--	3	Large Monitor Mount
--	8	3" Standoff Barrel
--	1	8" x 12" Monitor Mounting Plate
--	4	1" Standoff Barrel

- Steps:
- 1) Connect monitor mounts to left & right panels as shown.
See **Monitor Mount Attachment** detail.
 - 2) Attach Closet Monitor Mount closet panels [8/9], using mounting plate & bolts. See **Closet Monitor Mount Attachment** detail. **Note: Closet monitor mount is not used for alternate configuration. See next page.**
 - 3) Attach PR63 conduit to vertical extrusions for wire management.
See **PR63 Attachment** detail.

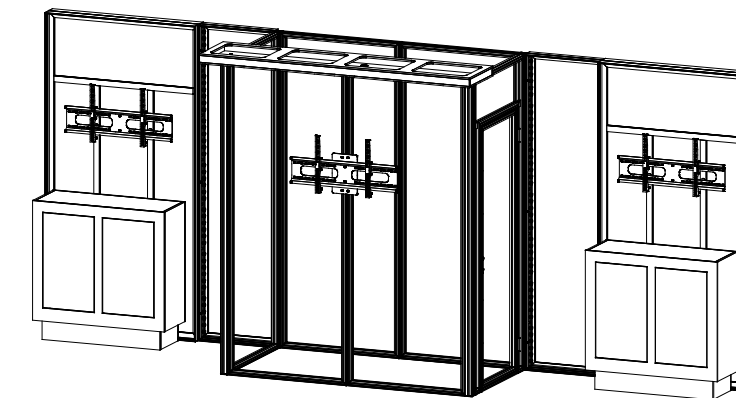

Completed Assembly

*** Closet Monitor Mount Attachment**

1. Slide V4 connectors into grooves of Gravitee panels; tighten set screws to secure connectors in place.
2. Attach Standoff Barrels to V4 connectors, then attach Mounting Plate to standoff barrels, using bolts.
3. Connect Monitor Mount to mounting plate, using bolts.

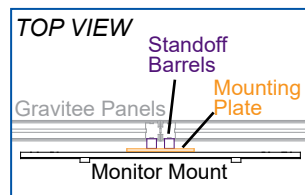
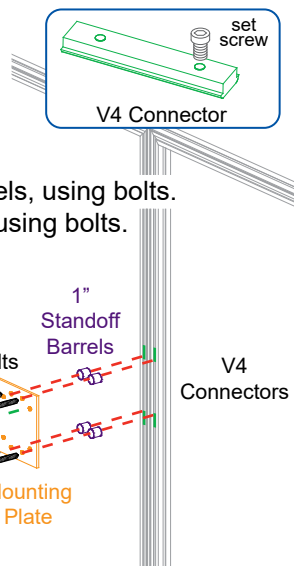

Standoff barrels attach through SEG graphic.

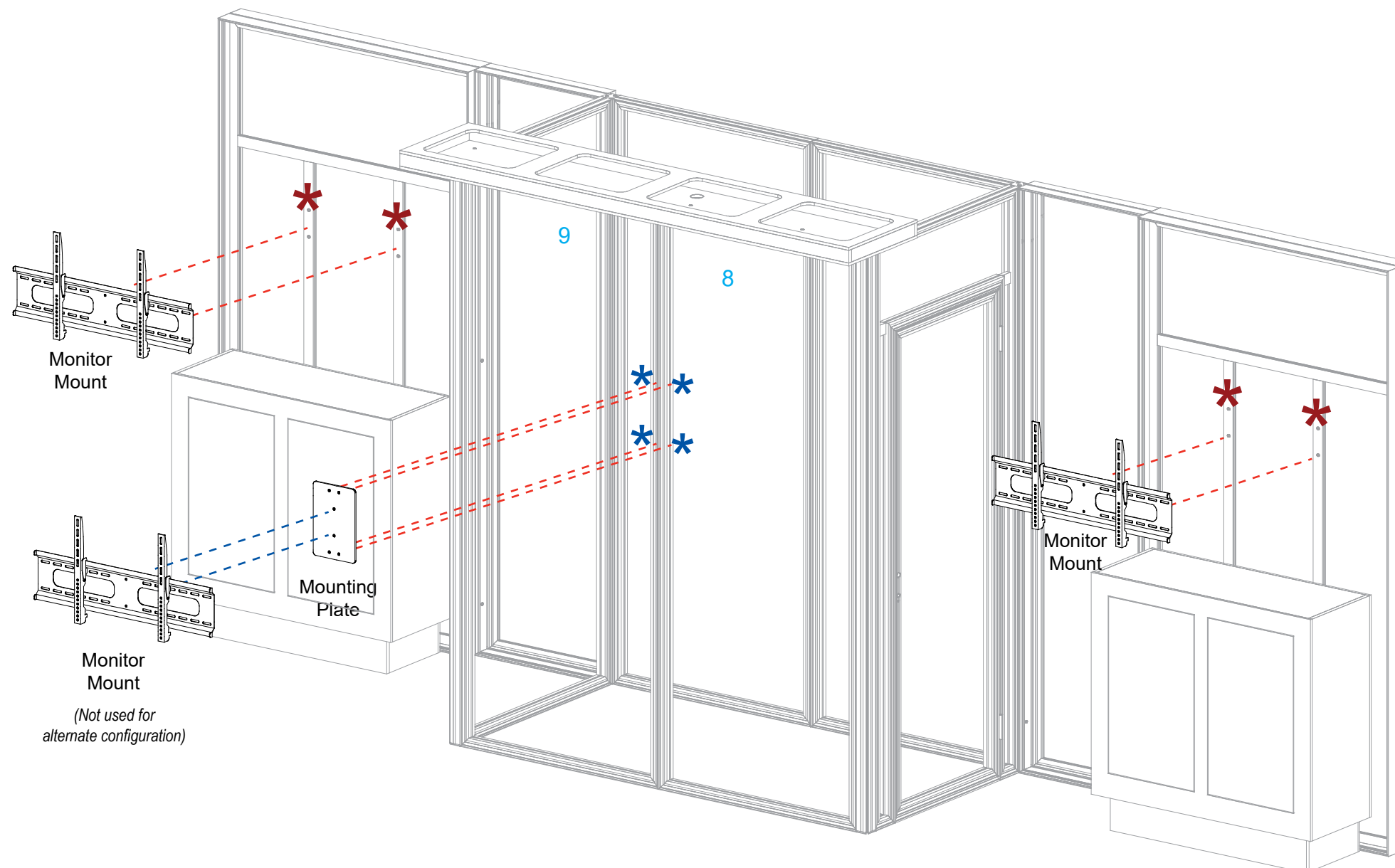

*** Monitor Mount Attachment**

Attach Stand-off barrels to Z45 extrusions & secure with wing nuts.

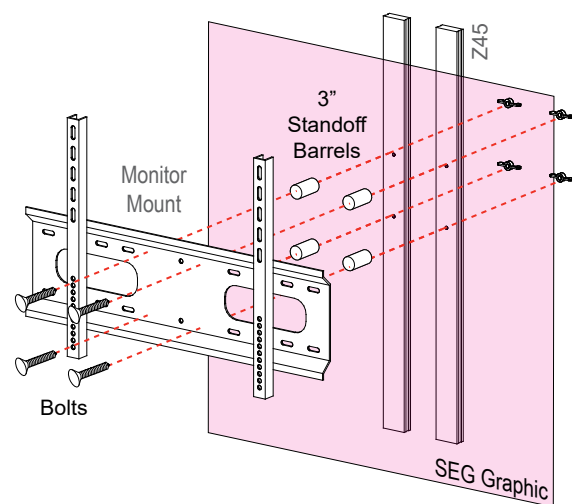

Connect Monitor Mount to Standoff Barrels using Bolts.

Note: Monitor mounts install through SEG graphic.

*** PR63 Attachment**

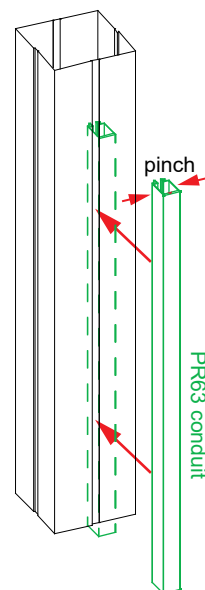

- 1) Run cords through PR63 plastic conduit.
- 2) Attach conduit where indicated by pinching the opening and inserting into the groove of extrusion.

Item	Qty.	Description
1/2	1/1	30.5"h CEI110 Vertical Extrusion
3/4	1/1	46"w CEI110 Horizontal Extrusion

- Steps:**
- 1) Connect horizontals [3,4] between verticals [1,2], sliding backer panel between verticals. See [CEI-110 Corner Connection](#) detail.
 - 2) Attach left & right cabinets to frame assembly [1/2/3/4] using bolts & wing nuts.
 - 3) Install [Counter Top](#) to assembly using standoff barrels. See [Standoff Barrel Attachment](#) detail.
 - 4) Connect power cords to Supernova lights as shown.
 - 5) Apply SEG graphic to frame.
- Refer to the [SEG Installation general information page](#).

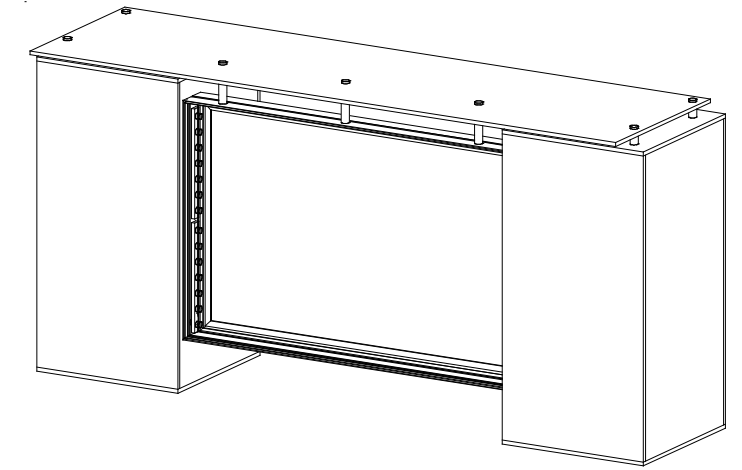
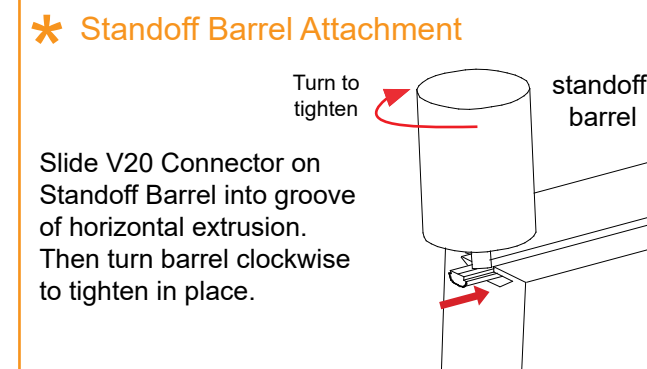
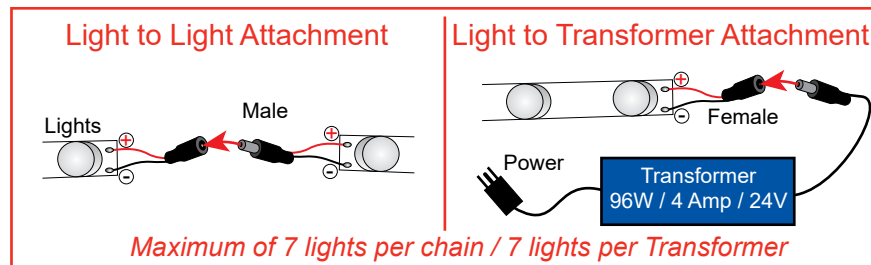
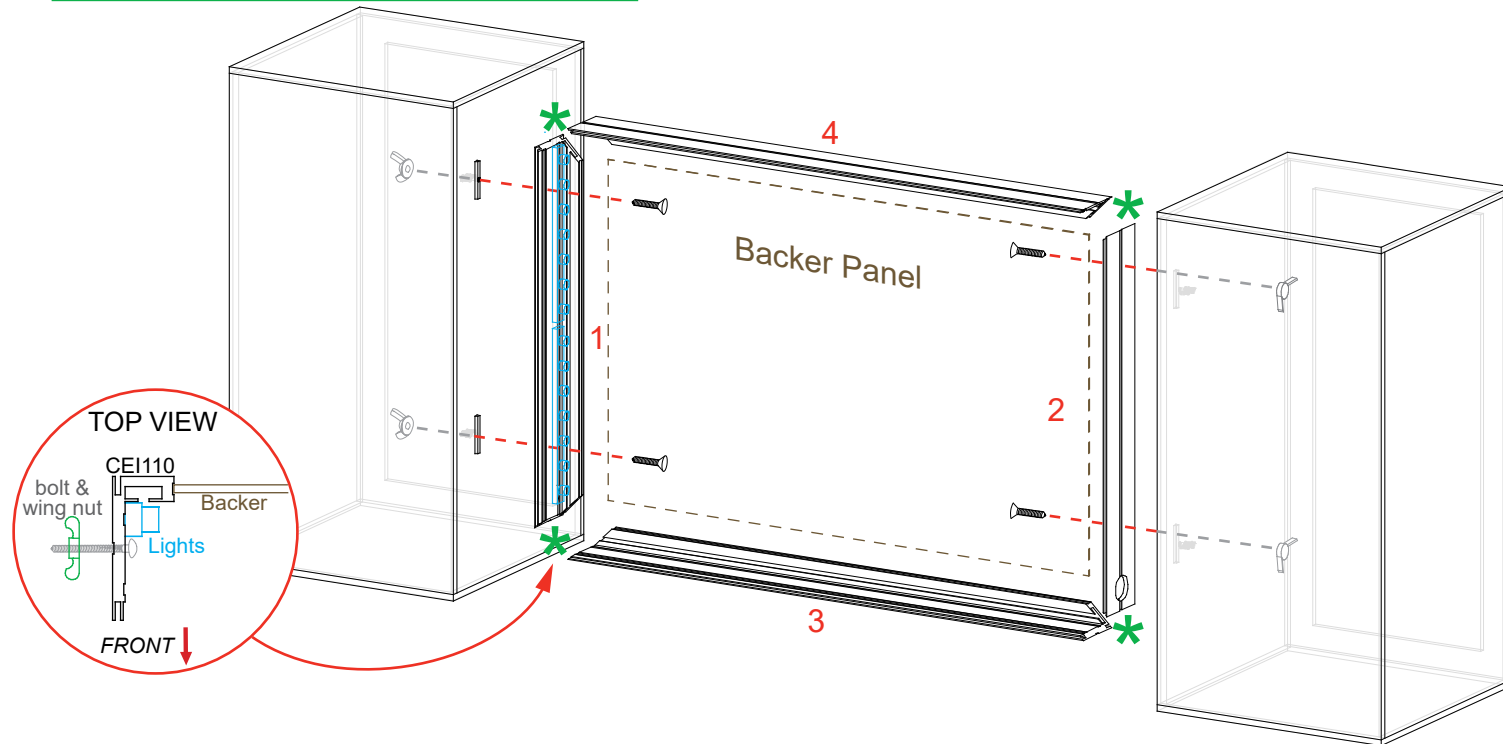
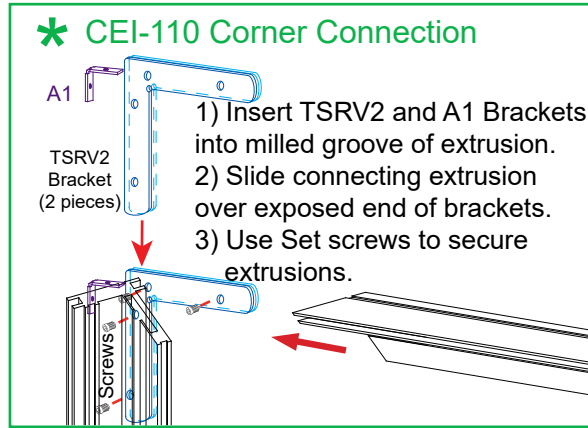

When assembled

